

Brown Davis Automotive Pty. Ltd.
 ABN: 72 657 573 544

Copyright Brown Davis Automotive Pty. Ltd. This document contains technical information the property of Brown Davis Automotive Pty. Ltd.

**TOYOTA LANDCRUISER 80 SERIES - WAGON – 175lt REPLACEMENT TANK
 LONG RANGE FUEL TANK PARTS LIST AND FITTING INSTRUCTIONS
 PART NUMBER: TL80R1**

Item #	Description	Quantity	Part No.	P	C
1	TANK—REPLACEMENT	1	TL80R1	-	-
2	DRAIN PLUG—MAGNETIC—M14 (FITTED TO THE TANK)	1	DP-M14	-	-
3	HOSE – FUEL EMISSION - 10mm	0.6m			
4	HOSE CLAMP – STAINLESS – 8-16mm	2			
5	HOSE CLAMP – STAINLESS - 12-22mm	2			
6	FUEL PICK UP – 3/8" x 1/4" BSP ELBOW	1			
7	BRASS – ELBOW - 1/4" x 1/4" BSP	1			
8	BRASS – TAIL BARB - 5/8" x 1/4" BSP	1			
9	BOLT – HEX – M10 x 65mm – PLATED 8.8	3			
10	NUT – STANDARD PLATED – M10	18			
11	WASHER – SHAKEPROOF INTERNAL PLATED – M10	9			
12	WASHER – FLAT PLATED – M10	9			
13	WASHER – PANEL PLATED – M10	9			
14	SET SCREW – HEX – M10 x 30mm – ON WIRE – PLATED 8.8	6			
15	SET SCREW – PAN HEAD – M5 x 12mm – PLATED 8.8	6			
16	WASHER – SPRING - M5	6			
17	CROSSMEMBER	1	CM-TL80R1		
18	MAGNETIC DISC (fitted in swirl pot)	1	FNR-038-044		
19	FUEL FLOAT EXTENSION WIRE - 220mm	2			
20	WARRANTY INFORMATION SHEET	1			
21	BROWN DAVIS AUTOMOTIVE STICKER	1			



CM-TL80R1- REFER TO ITEM 17

	STAFF MEMBERS INITIALS	DATE
KIT PACKED BY		
KIT CHECKED BY		

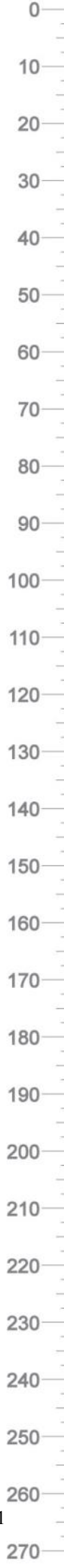

Brown Davis Automotive Pty. Ltd.
ABN: 72 657 573 544

Copyright Brown Davis Automotive Pty. Ltd. This document contains technical information the property of Brown Davis Automotive Pty. Ltd.

**PART NUMBER: TL80R1
175lt REPLACEMENT TANK
LONG RANGE FUEL TANK PARTS LIST AND FITTING INSTRUCTIONS**

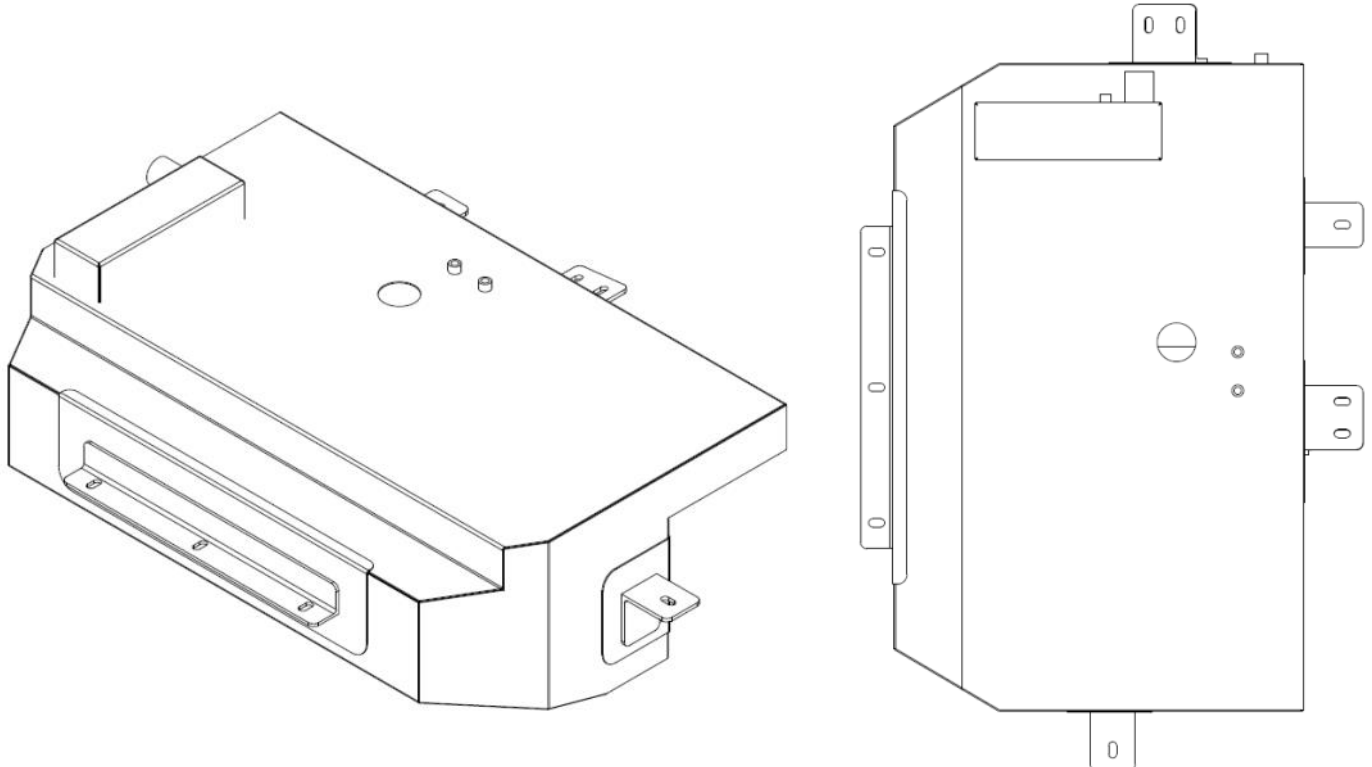

WARNING:

THIS FUEL TANK IS HEAVY. DO NOT ATTEMPT TO LIFT THIS FUEL TANK WITHOUT APPROPRIATE ASSISTANCE OR SERIOUS INJURY MAY RESULT



WARNING:

ENSURE A FIRE EXTINGUISHER IS AVAILABLE WHILST WORKING NEAR EXPOSED FUEL



-CHECK CONTENTS OF KIT BEFORE COMMENCING FITMENT

-DRAIN VEHICLE FUEL TANK TO LOWEST LEVEL POSSIBLE BEFORE COMMENCING FITMENT

-BEFORE INSTALLATION THE BROWN DAVIS LONG RANGE TANK SHOULD BE WASHED OUT WITH THE SAME FUEL TYPE AS THE VEHICLE IT'S BEING FITTED TO

Any questions or information required in relation to the below instructions please do not hesitate to contact Brown Davis head office or one of our distributors.

Phone: +61 (3) 9762 8722

Email: info@browndavis.com.au

Brown Davis Automotive Pty. Ltd.

47 Holloway Drive, Bayswater, Victoria, Australia 3153

Ph: +61 (3) 9762 8722 | Fax: +61 (3) 9762 9829 | Email: info@browndavis.com.au | Web: www.browndavis.com.au

Brown Davis Automotive Pty. Ltd.
ABN: 72 657 573 544

Copyright Brown Davis Automotive Pty. Ltd. This document contains technical information the property of Brown Davis Automotive Pty. Ltd.

REMOVAL STANDARD OF STANDARD TANK

1.	Remove the spare wheel from under the rear of the vehicle then unbolt and remove the spare wheel wind up mechanism and chassis crossmember.	
2.	<p>Drain all the fuel from the standard sub tank.</p> <ul style="list-style-type: none">Remove the filler neck protective cover plate from under the right hand side rear wheel arch and disconnect the filler and fast fill breather hoses from the filler neck.Do not remove these hoses at their tank end at this stage.	
3.	<p>Disconnect the fuel pick up hose and return hose from the steel lines near the middle front of this standard rear sub tank.</p> <ul style="list-style-type: none">Do not disconnect these hoses from their respective tank fittings at this stage.	
4.	Unbolt the standard rear sub tank and carefully lower it, until you can access the fuel gauge wiring and unplug it. Then lower tank to the ground.	

Brown Davis Automotive Pty. Ltd.
ABN: 72 657 573 544

Copyright Brown Davis Automotive Pty. Ltd. This document contains technical information the property of Brown Davis Automotive Pty. Ltd.

SETUP OF REPLACEMENT TANK

5. Remove the fuel gauge sender unit from this standard rear sub tank. Modify this unit and then refit the fuel gauge sender unit into the new long range tank using the original screws and gasket.

⇒ **NOTE:** Petrol models will also need the pump shut off arm extended. An extra wire piece is in the kit for this.



Brown Davis Automotive Pty. Ltd.
ABN: 72 657 573 544

Copyright Brown Davis Automotive Pty. Ltd. This document contains technical information the property of Brown Davis Automotive Pty. Ltd.

6. Install all brass fittings into the new replacement long range fuel tank using Teflon tape, thread sealant or the likes on all threads.

- ⇒ **FUEL PICK UP – 3/8" x 1/4" BSP ELBOW - Circled in Red**
- ⇒ **BRASS – ELBOW - 1/4" x 1/4" BSP - Circled in Blue**
- ⇒ **BRASS – TAIL BARB - 5/8" x 1/4" BSP - Circled in Green**

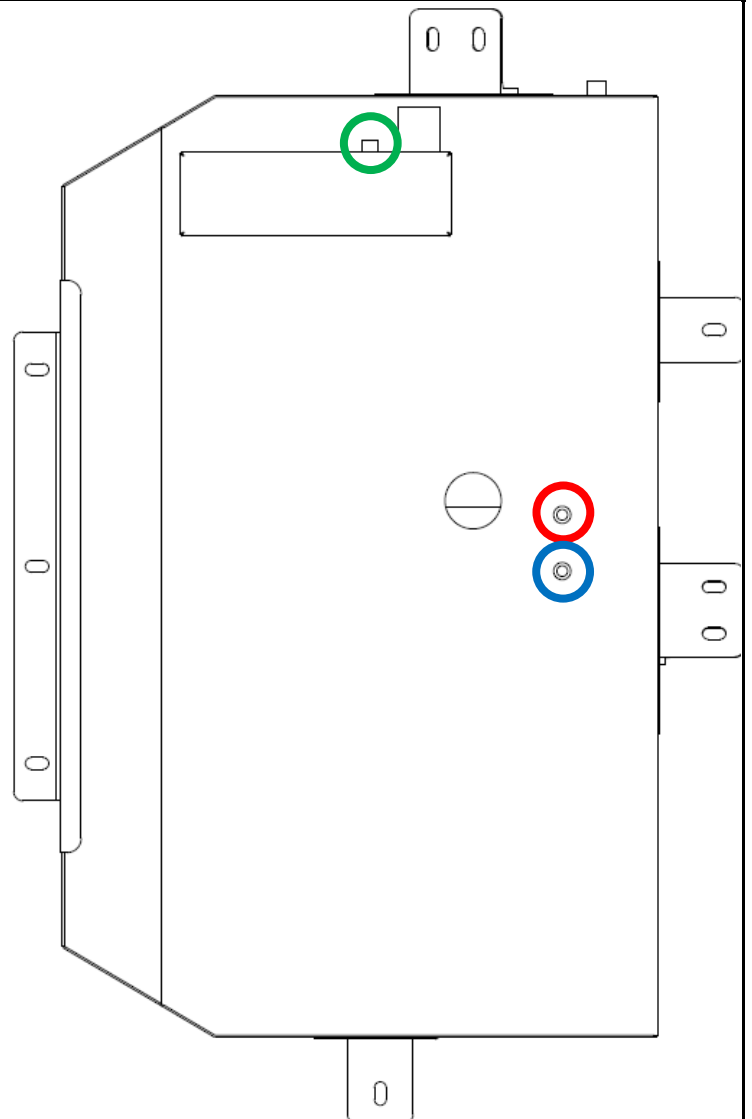

7. Transfer the filler and fast fill hoses to the new long range tank.

- ⇒ The Fast fill connects to the **BRASS – TAIL BARB - 5/8" x 1/4" BSP.**

Brown Davis Automotive Pty. Ltd.
ABN: 72 657 573 544

Copyright Brown Davis Automotive Pty. Ltd. This document contains technical information the property of Brown Davis Automotive Pty. Ltd.

INSTALLATION OF REPLACEMENT TANK

8. Bolt the supplied crossmember into the captives at the rear of the chassis.



8. Lift the new tank into position at an angle up on the passenger side to allow the filler and fast fill hoses to be fed over the chassis. Remember to reconnect the wiring to the fuel gauge sender unit as one lifts the tank into position. Hold in place with a jack or similar, and then drill holes through the new bracket locations including those through the chassis. Attach wires to the heads of the new bolts supplied and, using existing adjacent holes in chassis, lower bolts into new holes drilled. Fit washers and double nuts supplied, and tighten.

9. Connect all hoses to their original positions noting it will be necessary to trim the filler and fast fill hoses before reconnecting to suit the new tank positioning. Refit the cover plate over the filler area under the passenger side rear.

10. Double check all fuel line clamps and security of fuel lines. Fill tank and check for leaks. Road test and check for rattlers & squeaks. Re-check for fuel leaks.
- On some diesel vehicles it is necessary to bleed the fuel system after such a tank installation (refer manufacturers handbook). Confirm the fuel gauge is reading and replace the fuel cap.