

# PIRANHA OFFROAD PRODUCTS

BTGQP

'Piranha Off Road products are not associated in any way with Nissan Motor Co. (Australia) Pty Ltd or any of its related companies'

To Suit **NISSAN PATROL GQ**  
**TB 42 E 4.2L PETROL**



PART NUMBER	BTGQP
APPROX FITTING TIME	1 Hour
MAX BATTERY SIZE	235mm Long
RECOMMENDED TYPE	Cycle Duty
TRAY LOCATION	PSR

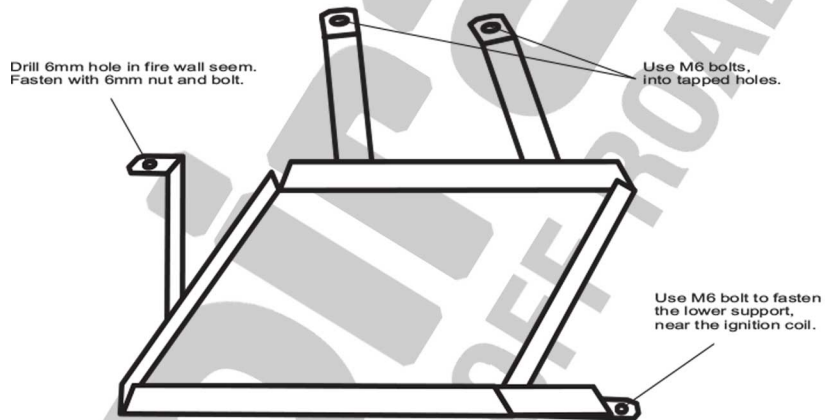
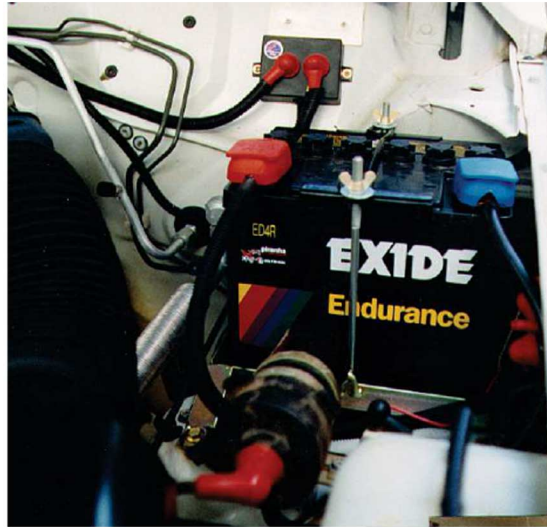

## PARTS INCLUDED WITH TRAY

- 4 X M6 Bolt
- 1 X M6 Nuts
- 2 X J Bolts
- 1 X Universal Top Mount

## FITTING INSTRUCTIONS

**The cradle fits passenger side rear.**

First bolt the two support arms into the left guard using M6 bolts into two original tapped holes. Bolt the bottom arm into tapped hole near the ignition coil. Note the coil may need to be moved slightly. The other support arm that rests against the fire wall needs a 6mm hole drilled, then fastened with M6 nut and bolt.

**Ensure, before closing the bonnet that all items fitted have adequate clearance**

## RECOMMENDED ISOLATOR

**DBE140S**  
or  
**DBE180-SX**